

# Vertical Lathe

»»» Single Column



## Main Structure

### Feature

This machine is suitable for mechanical processing of all industries. It can be used for rough and finish processing of inside and outside cylinder, cone surface, end face, grooving and cutting, as well as boring internal hole.

### Basic Parts

The foundation part is whole casting structure, using high strength and low stress cast iron material, annealing after casting, aging treatment after rough machining. The column guide rail adopt grinding processing, beam guide and ram guide adopt grinding processing after the intermediate frequency quenching.

### Worktable

Main transmission is driven by AC motor, main drive speed changing with 16steps is controlled by solenoid valves. All gears in the gear-box adopt high frequency quenching process.

Worktable adopts the type of rolling guideway, so large loading capacity of worktable and high turning precision.

### Tool-post

Vertical tool-post is equipped with five station tool-post, and adopts high precision rat-gear disk positioning, side tool-post is equipped with four-station tool-post. Both tool-posts adopt hydraulic balance. Horizontal and Vertical feed of vertical tool-post use the sliding screw driving; vertical and horizontal feed of side tool-post adopt gear-rack driving. Both tool-post are driven by 3-ph AC motor, the type of guideway is sliding guide rail, and the guideway paste high strength PTFE soft belt.

### Function Parts

Hydraulic system is equipped with German traffic transmission device, to guarantee oil flow stability for the workbench lubricating.

The machine uses PLC control, high reliability, electrical wiring in accordance with the process execution.

Beautiful appearance, agreeableness, convenient operation and maintenance.

According to customer's special requirement, we can provide digital display device, T-type ram and square ram.

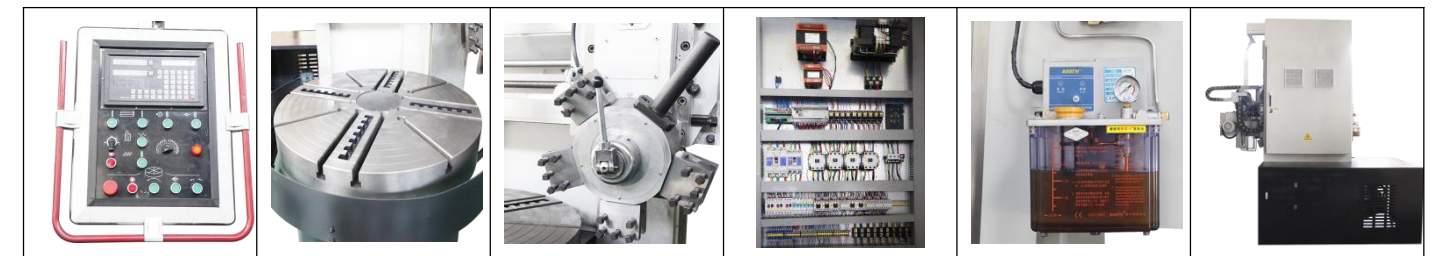

## Technical Parameter

Specifications	Units	VL1250E	VL1600E	VL2000E	VL2300E
<b>Capacity</b>					
Max. turning diameter	mm	1250	1600	2000	2300
Max. height of workpiece	mm	1000/1250 /1400	1000/1250/ 1400/1600	1250/1600	1250/1600
Max. weight of workpiece	kg	5000	8000	12000	12000
Worktable diameter	mm	1010	1400	1800	2000
Max. cutting force of vertical tool-post	KN	20	25	25	25
Max. cutting force of side tool-post	KN	20	20	20	20
<b>Worktable</b>					
Max. torque of worktable	KN.m	17.5	25	32	32
Worktable speed range/steps	rpm	6.3-200 (16)	5-160 (16)	4-125 (16)	3.2-100 (16)
<b>Feed</b>					
Vertical tool-post feed speed	mm/min	0.8-86 (12)	0.8-86 (12)	0.8-86 (12)	0.8-86 (12)
Tool-post rapid feed speed	mm/min	1800	1800	1800	1800
<b>Travel</b>					
Vertical tool-post swivel angle	°	±30°	±30°	±30°	±30°
Vertical tool-post cross travel	mm	-28-733	-15-930	-65-1150	-86-1300
Vertical tool post vertical travel	mm	650/800	800/1000	800/1000	800/1000
Side tool-post cross travel	mm	630	630	630	630
Side tool-post vertical travel	mm	900	900	900	900
<b>Others</b>					
Main motor power	kw	22	30	37	37
Machine dimensions (LxWxH)	cm	236x230x358	283x287x387	321x297x420	370x339x424
Machine weight	t	8.3/8.6/8.9	12.6/13.8/14.1	17.5/17.8	18.8/19.5

Note: Side tool-post is optional.

## Vertical Lathe

»»» Double Column

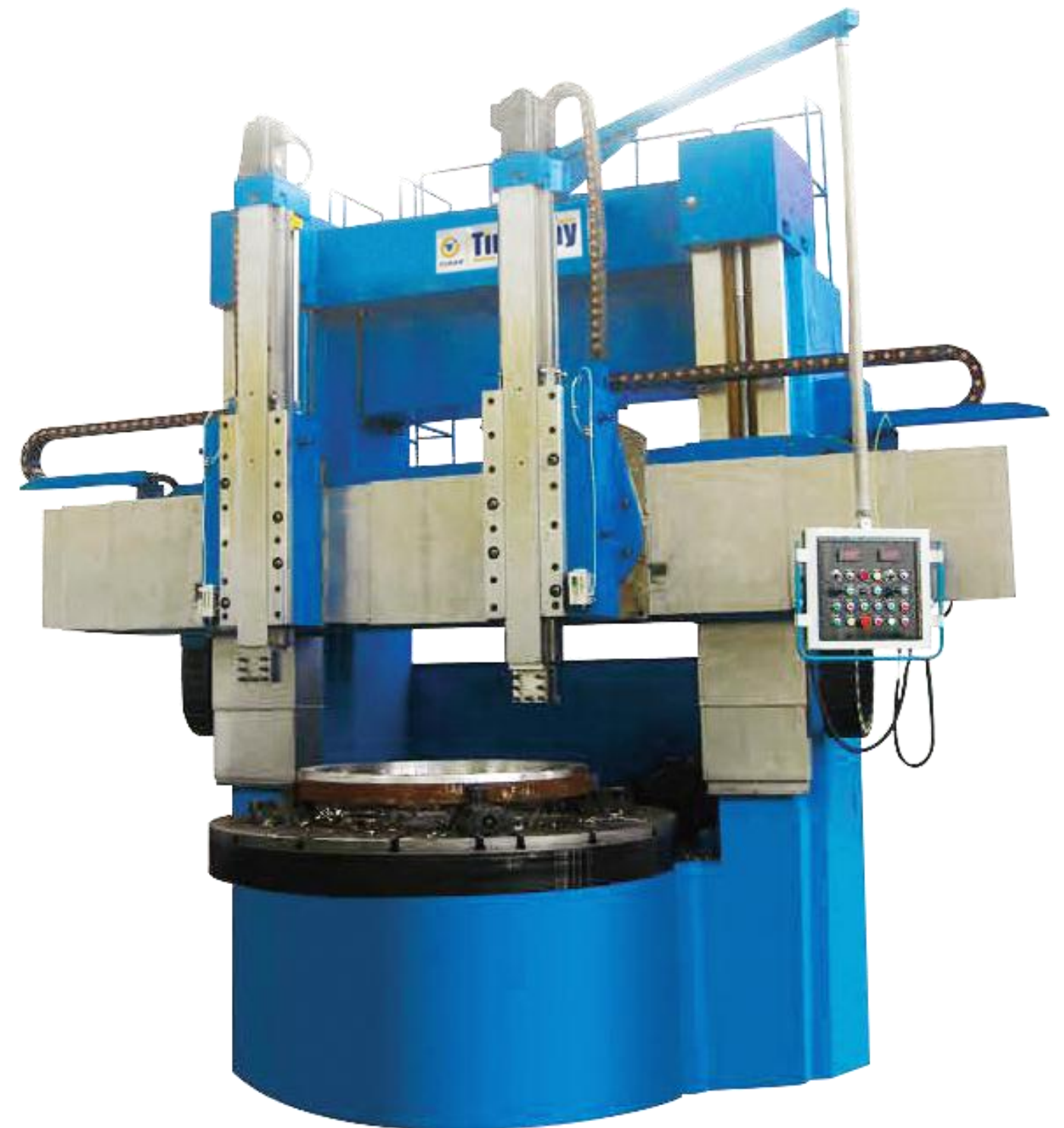

## Main Structure

### Feature

The machine tools are suitable for motor, water turbine, aviation, mining machinery, metallurgy and common machinery industries, and are used for rough and finish machining of inside and outside cylinder, cone surface, end face and grooving.

### Basic Parts

The foundation part is whole casting structure, using high strength and low stress cast iron material, annealing after casting, aging treatment after rough machining. The column guide rail adopt grinding processing, beam guide and ram guide adopt grinding processing after the intermediate frequency quenching.

### Worktable

Main transmission is driven by AC motor, main drive speed changing with 16steps is controlled by solenoid valves. All gears in the gear-box adopt high frequency quenching process. Worktable can adopt sliding, static pressure and rolling guide.

### Tool-post

Horizontal and Vertical feed of vertical tool-post use the ball screw driving, driven by AC servo motor, so as to realize automation. Left and right tool-post adopt hydraulic balance, using sliding guideway in the horizontal and vertical direction, and the guideway paste high strength PTFE soft belt.

### Hydraulic & PLC Control

Hydraulic system is equipped with German traffic transmission device, to guarantee oil flow stability for the workbench lubricating.

The machine uses PLC control, high reliability, electrical wiring in accordance with the process execution.

### Function Parts

Beautiful appearance, agreeableness, convenient operation and maintenance.

According to customer's requirement, we can provide motorized spindle grinding head, cooling device, DRO and etc.

Equipped with CNC system according to customer's need.

Adopt Chinese famous quality products.

## Technical Parameter

Specifications	Units	VDL2500E	VDL3150E	VDL3500E	VDL4000E
<b>Capacity</b>					
Max. turning diameter	mm	2500	3150	3500	4000
Max. processing height of workpiece	mm	1600/2000/2500	1600/2000/2500	1600/2000/2500	1600/2000
Max. height of workpiece	t	12/16	12/16	12/16	12/16
Max. cutting force of vertical tool-post	KN	35(right)/30(left)	35(right)/30(left)	35(right)/30(left)	35(right)/30(left)
Max. torque of worktable	KN.m	63	63	63	63
<b>Worktable</b>					
Worktable diameter	mm	2250	2500/2830	2830/3150	3150/3600
Worktable speed range	rpm	2-63 (16)	2-63 (16)	2-63 (16)	2-63 (16)
<b>Feed</b>					
Tool-post feed speed range (stepless)	mm/min	0.2-500	0.2-500	0.2-500	0.2-500
Tool-post rapid feed speed	mm/min	3000	3000	3000	3000
<b>Travel</b>					
Tool-post swivel angle	°	±30°	±30°	±30°	±30°
Tool-post cross travel	mm	1400	1730	1920	2165
Ram vertical travel	mm	1000/1250	1000/1250	1000/1250	1000/1250
<b>Others</b>					
Tool shank section	mm	40x50	40x50	40x50	40x50
Main motor power	kw	55	55	55	55
Machine dimensions (LxWxH)	cm	504x440x620	639x465x560	746x540x620	795x752x620
Machine weight	t	32.4/34.4/36.5	36/37/38	40.1/42.2/44.4	42/44



# CNC Vertical Lathe

»»» Single Column

»»» Double Column



Zhengzhou Timeway Machine Tool Co., Ltd. professionally committed to the development and manufacture of vertical lathes. This series of machine tools is suitable for the machining of large, thin, heavy and other irregular workpieces; when there is no horizontal lathe, the roundness error caused by the inertia of the workpieces is ensured, and the roundness accuracy of the workpieces is ensured; because of the weight of the workpieces, the workpiece is It can ensure close contact with the fixture, and the loading and unloading time of the workpiece is short and stable. The column, beam and ram rails are all quenched and then ground to give them superior wear resistance and long service life. The unique closed machine Protective cover, placing chips, coolant splashes, to achieve environmental protection.





**VLK series**  
Overall Machine



**Main Structure**

**Column**

The column adopts the optimization design of box-type structure and reasonable layout stiffener, so as to realize the good thermal stability, high strength and high rigidity. The column guideway adopts grinding after quenching, to improve wear resistance and prolong service life. The guideways adopt stainless steel sealing cover for protection and reduce the corrosion rate.

VLK-series column guideway width

Model	Guideway width
VLK800E	1070
VLK1250E	1190
VLK1600E	1460
VLK2000E	1970

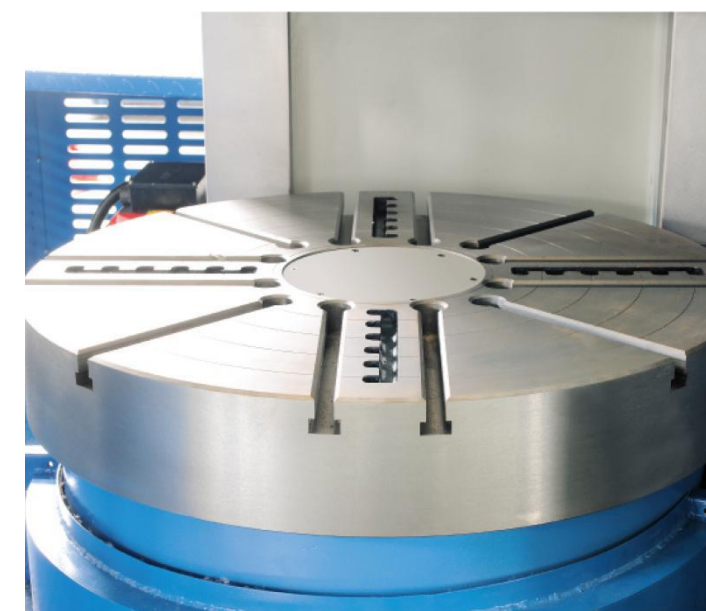

**Worktable Base**

The worktable base adopts high strength and high rigid cast iron material, to improve stability and absorb vibration. Unique thermal symmetric structure, overcome the spindle temperature rise effect on machining accuracy.

The spindle is equipped with spindle encoder, to realize constant linear speed cutting

Worktable and worktable base and motor separation, relying on the V-type belt drive, max. limit reduces the vibration of the motor heat directly affect the machining accuracy.

## Main Structure

### Worktable

The worktable adopts high strength and high rigid cast iron material, to improve stability and absorb vibration.

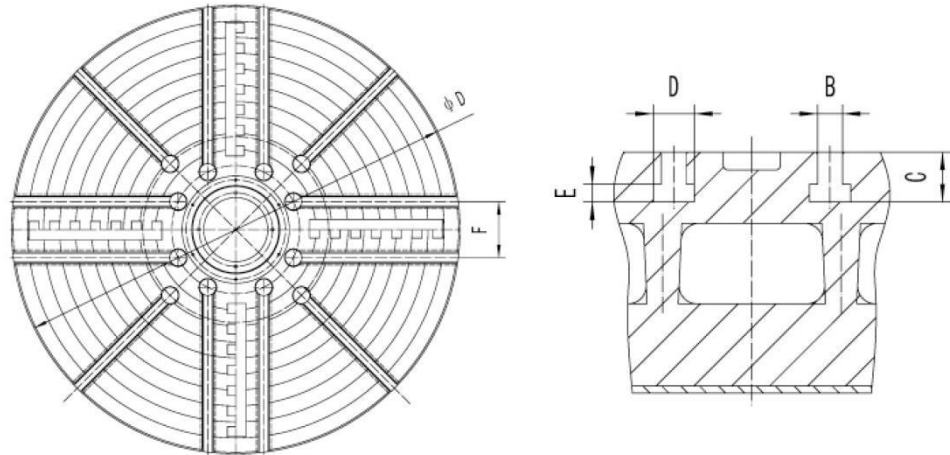

VLK-series worktable size						
Model	Worktable diameter	T-slot(B)	T-slot(C)	T-slot(D)	T-slot(E)	T-slot(F)
VLK800E	Φ800	18	37	30	14	110
VLK1250E	Φ1010	22	39	36	16	125
VLK1600E	Φ1400	28	56	46	20	175
VLK2000E	Φ1800	28	56	46	20	175

### Spindle Unit

Worktable uses integrated, high rigidity, high precision and short fixed-type spindle structure, the spindle is equipped with a set high precision thrust ball bearing and a set double row short cylindrical roller bearing. Compact structure, at the same time bear radial load, the axial load and tilting moment, and under the overloading elastic deformation is small, improved the precision of the rotation of the worktable and carrying capacity.

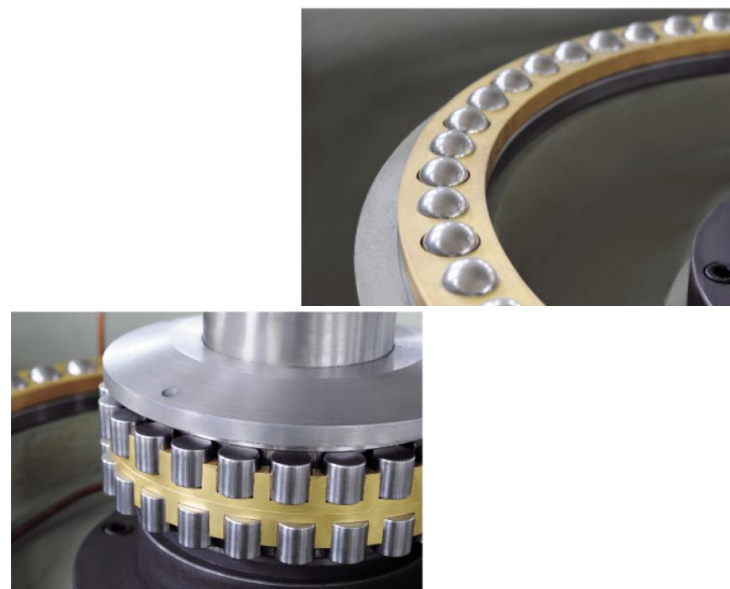

## Main Structure

### Beam

The beam guideway has very high wear resistance after quenching and grinding, so as to guarantee long-term stability and high processing accuracy.

Horizontal guideway width large with wide guide structure, ball screw in the middle of the guide rail thoroughly solve the problem of drive torque, the guideway adopts the paster guide rail, good seismic performance, large loading capacity, decrease friction coefficient.

Beam lifting adopts two clamping points, to ensure the accuracy of the lifting beam.



VLK-series beam guideway width				
Model	VLK800E	VLK1250E	VLK1600E	VLK2000E
Width	500	500	550	550

### Feed Unit

Tool-post horizontal feed(X-axis) and ram vertical feed(Z-axis) are driven by AC servo motor through the gear reducer driving ball screw, the reducer and screw through the flexible coupling connection, high transmission efficiency, small transmission error, high transmission precision.

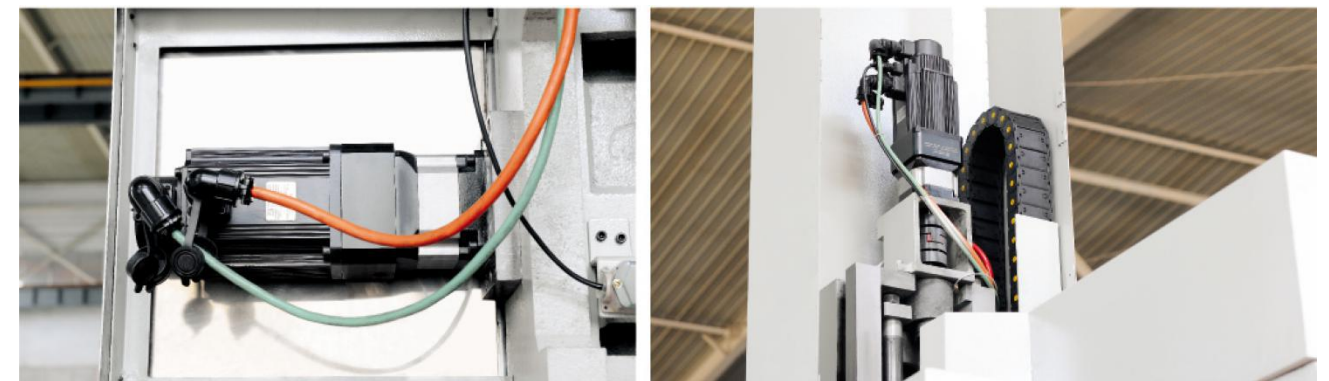



## Main Structure

### Main Transmission System

Main transmission adopts gear drive, gears adopt high strength material and quenching and grinding process, so it can realize high speed cutting force, high transmission accuracy and rate, and reduce the vibration and noise of the transmission.

Main transmission is controlled by horizontal spindle servo motor, can realize four shifts stepless speed, it is suitable for processing all material workpiece, to realize spindle wide speed changing and large torque heavy cutting, meet low-speed and heavy cutting for big diameter workpiece, and high-speed cutting for smaller diameter workpiece.

Large gear adopt high grade alloy steel, through quenching treatment and being ground by high precision gear grinding machine, to reduce noise of spindle running.

Unit: rpm

	Spindle speed range			
Shifts	VLK800E	VLK1250E	VLK1600E	VLK2000E
I	2-20	1.26-2.5	1-10	0.8-8
II	5-50	3.2-32	2.5-35	2-20
III	12.5-125	8-80	6.3-63	5-50
IV	16-320	20-200	16-160	12.5-125



### Four Station Electrical Tool-Post

High Positioning accuracy, large clamping force, large loading capacity, stable and reliable.

The unique dovetail cutter holder, more accurate positioning, greater clamping force.



## Main Function Part

### Electrical Cabinet

Electrical cabinet placed directly within the column, so the structure is more compact, save space. Beautiful appearance, wire marking clear and complete, wiring and tidy; The connection of the electrical cabinet to bed adopt the special cable connection.

Electrical cabinet is equipped with air condition, safety and standard, to ensure controller constant temperature, the stability of the controller.



### Precision Oil Cooler

Precision oil cooler can prevent the machine tool thermal deformation, stable oil pressure, prevent oil shock, improve the processing precision, reduce the error of the mechanical action, reduce maintenance costs of machine tool through cooling hydraulic oil of machine tool.



### Automatic Lubrication Pump

Guideway and screw adopt centralized lubrication, use a set automatic lubrication station, through the control of the electric system can all lubricating points for quantitative regularly, lubrication operation is more simple.



## Spindle P/T Diagram

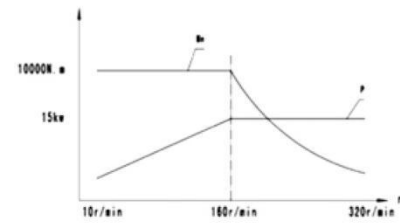

VLK800E

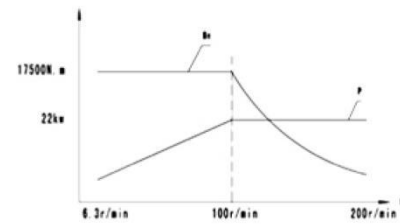

VLK1250E

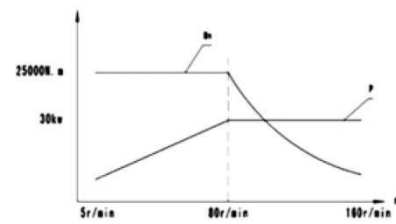

VLK1600E

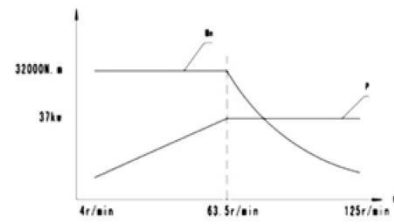

VLK2000E

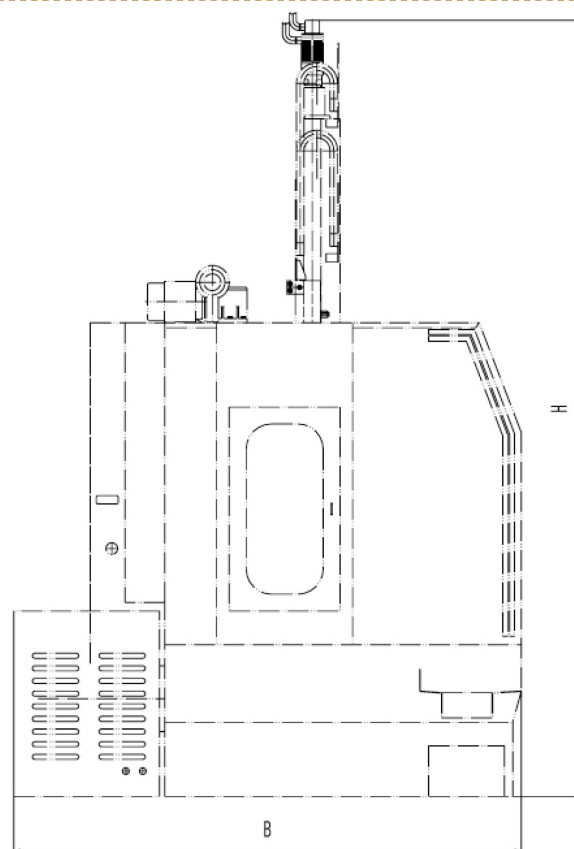
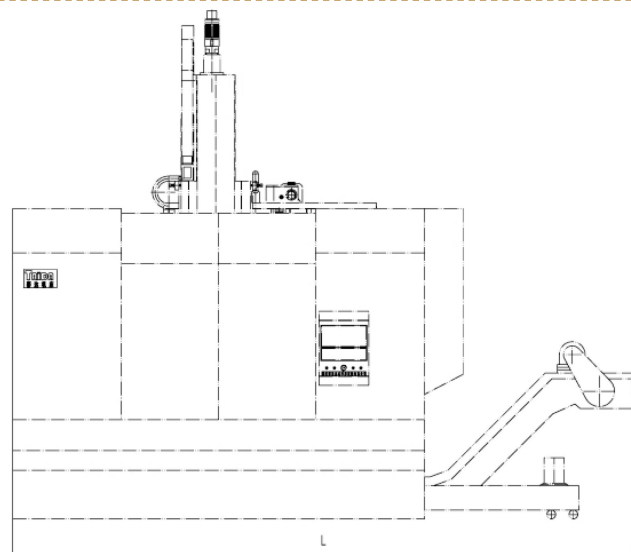

VLK-series machine dimensions

Model	Length(L)	Width(B)	Height(H)
VLK800E	4300	2380	4290
VLK1250E	4780	2570	4400
VLK1600E	5630	3010	4660
VLK2000E	5800	3685	4940

## Technical Parameter

Specifications	Units	VLK800E	VLK1250E	VLK1600E	VLK2000E
<b>Capacity</b>					
Max. turning diameter	mm	950	1250	1600	2000
Max. cutting diameter	mm	800	1250	1600	2000
Max. height of workpiece	mm	800	1000	1000	1250
Max. weight of workpiece	kg	2000	5000	8000	12000
<b>Worktable</b>					
Main motor power	kw	22	22	30	37
Worktable diameter	mm	800	1010	1400	1800
Max. torque of worktable	KN.m	10	17.5	25	32
Worktable speed range	rpm	2-320	1.25-200	1-160	4-125
<b>Tool</b>					
Number of tool station	pcs.	4	4	4	4
Tool shank section of external turning tool	mm	32x40	32x40	32x40	32x40
Drive type	-	Electric	Electric	Electric	Electric
<b>X/Z-axis</b>					
X-axis ball screw size (dia. x screw pitch)	mm	50x10	50x10	50x10	50x10
Z-axis ball screw size (dia. x screw pitch)	mm	50x10	50x10	50x10	50x10
Max. travel(X/Z)	mm	-20~550/650	-20~800/650	-20~1030/800	-20~1150/800
Feed range(X/Z)	mm	0.1-500	0.1-500	0.1-500	0.1-500
Rapid feed speed	mm/min	2000	2000	2000	2000
<b>Others</b>					
CNC system	-	SIEMENS	SIEMENS	SIEMENS	SIEMENS
Servo motor torque(X/Z)	N.m	10	10	10	10
Power capacity	Kva	30	37	45	52
Machine net weight	kg	8500	11000	14500	18500
Machine dimension (LxWxH)	cm	430x238x429	478x257x440	563x301x466	580x368x494





The series CNC double column vertical lathe is designed by absorbing modern advanced design and manufacturing techniques and using CAD optimization design method, using the latest design concept and equipping with domestic and foreign advanced features.

Realize strong cutting on the structure performance, the worktable overweight load, machine high dynamic and static stiffness, all movement safety and stability, long service life and high processing efficiency.

The machine is suitable for high speed steel and carbide cutting tools, processing workpieces of all ferrous and non-ferrous metals and some nonmetal materials.

The machine can complete the process of rough and finish turning inside and outside cylinder, inside and outside cone surface, plane surface, the circular arc surface and grooving.

## VDK series Overall Machine

- » Single vertical tool head
- » Double vertical tool head



## Main Structure

### Gantry-frame

1. The series lathe adopts frame-type gantry structure with double column and connection beam. Both column and beam adopt high strength and low stress cast iron parts with material toughness, proper annealing treatment, plus box-type structure design, high rigid body structure, to guarantee mechanical features of heavy cutting resistance ability and high stability.
2. Equipped with retractable stainless steel enclosures prevent slippery, to protect the screw and guide rail.
3. The beam and column guideway adopt grinding process after intermediate frequency quenching, quenching hardness is 45 to 55HRC.

### Worktable

1. The worktable base adopts high strength and high rigid cast iron material, to improve stability and absorb vibration. Unique thermal symmetric structure reduces thermal deformation of worktable, to ensure the worktable a long-term stability. Workbench and column are installed respectively on the base after the connection, the overall structure of the machine more stable.
2. The spindle is equipped with spindle encoder, to realize constant linear speed cutting.
3. Workbench with T-slots, including double T-slots used to install the chuck claw, single T-slot used to install auxiliary fixture and accessories.

### Main Drive

1. Main transmission is driven by horizontal AC servo main motor, main motor and gear-box connect through spring coupling, variable speed drive by vertical mechanism, realize turning the required speed range. AC servo gear-box adopts horizontal four shifts stepless gear-box, suitable for processing all material workpiece.
2. Changing speed is controlled by electromagnetic valve controlling oil cylinder and oil-way, in order to prevent shifting cylinder pressure relief, equipped with pressure relay, in controlling the oil accumulator machine hydraulic lock mechanism, to ensure reliable transmission. All gears in gear-box adopt quenching and grinding, so gain high transmission precision and efficiency, and reduce the transmission vibration and noise.

### Feed

Left and right vertical tool-post horizontal feed(X,U-axis) and ram vertical feed(Z,W-axis) are driven by AC servo motor through the gear reducer driving ball screw, the reducer and screw through the flexible coupling connection, high transmission efficiency, small transmission error, high transmission precision.

## Technical Parameter

Specifications	Units	VDK2500E	VDK3150E	VDK3500E	VDK4000E
<b>Capacity</b>					
Max. turning diameter	mm	2500	3150	3500	4000
Max. height of workpiece	mm	1600/2000/2500	1600/2000/2500	1600/2000/2500	1600/2000
X-axis travel	mm	1400	1730	1920	2165
U-axis travel	mm	1400	1730	1920	2165
Z-axis travel	mm	1000	1000	1000	1000
W-axis travel	mm	1000/1250	1000/1250	1000/1250	1000/1250
Beam travel	mm	1250	1250	1250	1000
<b>Worktable</b>					
Worktable diameter	mm	2250	2500/2830	2830/3150	2830/3150
Max. weight of workpiece	kg	12000/16000	12000/16000	12000/16000	12000/16000
Worktable speed steps	steps	4 shift, stepless	4 shift, stepless	4 shift, stepless	4 shift, stepless
Worktable speed range	rpm	2-63	2-63	2-63	2-63
Main motor power	kw	60	60	60	60
Max. torque of worktable	KN.m	32	32	32	32
<b>Feed</b>					
Total cutting force	KN	63	63	63	63
Left/right vertical tool-post max. cutting force	KN	30/35	30/35	30/35	30/35
Left/right tool-post feed speed steps	-	stepless	stepless	stepless	stepless
Right tool-post feed speed range	mm/min	0.1-500	0.1-500	0.1-500	0.1-500
Right tool-post rapid feed speed	mm/min	3000	3000	3000	3000
Left tool-post feed speed range	mm/min	0.1-1000	0.1-1000	0.1-1000	0.1-1000
Left tool-post rapid feed speed	mm/min	4000	4000	4000	4000
Min. setting unit	mm	0.001	0.001	0.001	0.001
Beam lifting speed	mm/min	350	354	354	354
<b>Others</b>					
Ram section(square)	mm	220x220	220x220	220x220	220x220
Tool shank section	mm	40x50	40x50	40x50	40x50
Left/right tool-post swivel angle	°	±30°	±30°	±30°	±30°
Beam lifting motor power	kw	7.5	11	11	11
Total power	kw	70.6	78.1	78.1	78.1
Machine dimension(LxWxH)	cm	504x440x495	746x465x495	639x540x495	795x752x495
Machine weight	T	35/36/37	38/39/40	41/42/43	43/44
CNC system	-	SIEMENS	SIEMENS	SIEMENS	SIEMENS



# CNC Vertical Lathe CNC Vertical Turning Center

»»» High Speed

»»» Single Column

Zhengzhou Timeway Machine Tool Co., Ltd. professionally committed to the development and manufacture of vertical lathes. This series of machine tools is suitable for the machining of large, thin, heavy and other irregular workpieces; when there is no horizontal lathe, the roundness error caused by the inertia of the workpieces is ensured, and the roundness accuracy of the workpieces is ensured; because of the weight of the workpieces, the workpiece is It can ensure close contact with the fixture, and the loading and unloading time of the workpiece is short and stable. The column, beam and ram rails are all quenched and then ground to give them superior wear resistance and long service life. The unique closed machine Protective cover, placing chips, coolant splashes, to achieve environmental protection.

The CNC single-column high-speed vertical lathes is an excellent product designed and produced in accordance with the market demand, based on in-depth study and analysis of the structural characteristics of the current CNC vertical car, digesting and absorbing the technical advantages of the same type of products domestic and abroad. The machine adopts electromechanical and hydraulic integrated structure, the overall layout is compact and reasonable, and has the characteristics of small floor space, convenient installation and maintenance. The whole machine adopts a closed full protection structure, which is beneficial to safe production and reduces pollution to the production environment. The shape is in line with the principle of ergonomics, pleasant and easy to operate. It is especially suitable for the automotive, motorcycle industry, electronics, aerospace, military and other industries. It is used for high-efficiency and high-volume processing of disc and short-axis parts.

This machine is mainly composed of base, column, main drive system, feed system, tool holder, chuck cylinder, numerical control system, electrical system, hydraulic system, lubrication system, cooling system, whole machine protective cover and automatic chip removal device.



## VK series Overall Machine



## Main Structure

### Base and Column

The machine base structure is optimized, which is made of high-density cast iron and sand-covered structure, with high strength and good vibration absorption. The base and column ribs are arranged reasonably. The column is directly fixed on the base, with high rigidity. The base and the column use the special layout, make the lathe more compact and smaller in size, and at the same time improves the rigidity and precision of the machine.

### Main Drive System

The spindle unit is designed according to the high-rigidity spindle unit, which makes the whole unit highly accurate and rigid. The spindle unit adopts the double base speed motor as the main motor, with two shifts of high speed and low speed, which has high speed and output torque. The main drive adopts a narrow V-belt, and its transmission capacity is 0.5-1.5 times higher than that of the ordinary V-belt.

Due to different configurations, this machine has a variety of speed ranges, please refer to the maximum speed of the chuck and the maximum speed of the machine when using. If the maximum speed of the chuck is greater than the maximum speed of the machine, the speed at high speed should not exceed the maximum speed of the machine; if the maximum speed of the chuck is less than the maximum speed of the machine, the speed at high speed should not exceed the maximum speed of the chuck to prevent the dangerous caused by overload speed. If the machine is equipped with special fixtures or special jaws, it should be based on the speed limit plate on the special fixture or the actual maximum speed given in the adjustment card to avoid danger.

### Feed System

The X-axis and Z-axis guide rails adopt reinforced linear roller guides, which have extremely high rigidity and sharp dynamic response in the cutting state, and they are equipped with automatic lubrication devices. The guide rails have high precision and long service life, enabling fast response and high speed feeding performance. The X-axis and Z-axis ball screws are made of Taiwan's TBI high-precision ball screw pair. The Z-axis is equipped with a weight balance that overcomes the weight of the carriage and the tool holder, reduces motor load and extends the life of the screw.



## Main Structure

### Tool Post

The tool post adopts the Taiwan horizontal 8-station hydraulic tool holder, with high precision and good rigidity.

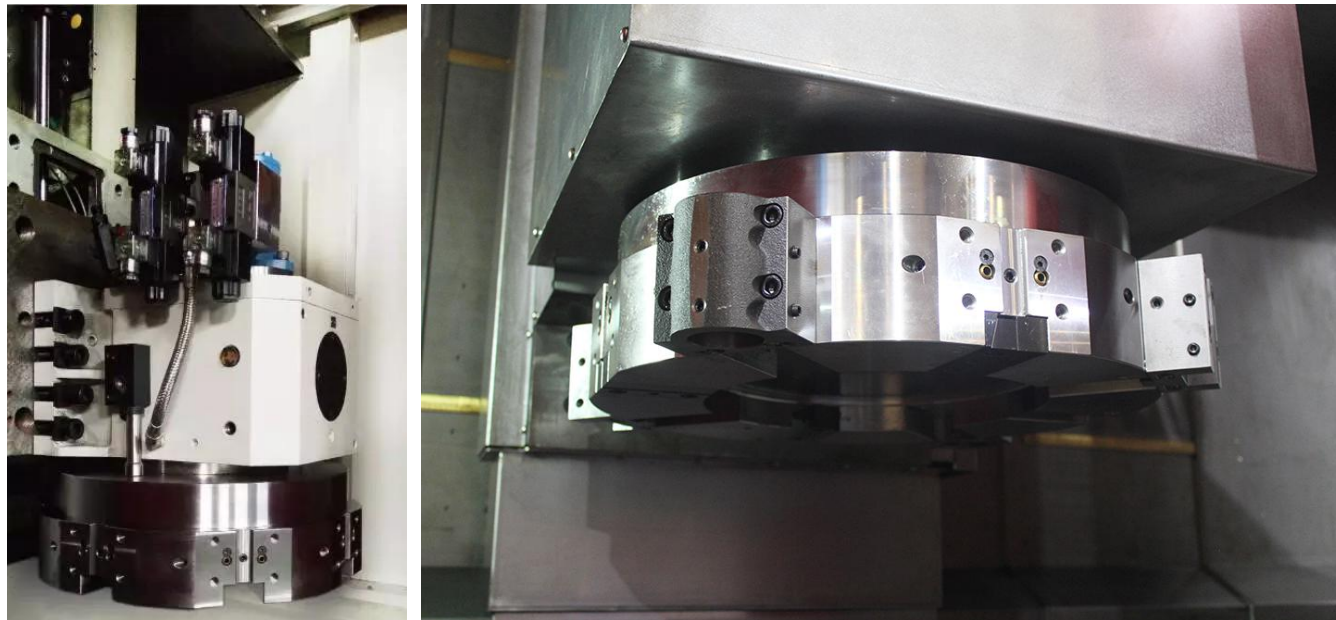

### Chuck cylinder

The machine is equipped with hydraulic automatic chuck as standard, with a clamping cylinder. The chuck adopts imported hydraulic chuck with waterproof and anti-dusting function and matching cylinders.



### Hydraulic System

This machine is a CNC machine with a high degree of automation. When the hydraulic chuck and hydraulic tool post are configured, the hydraulic oil tank is placed on the side of the base. Each hydraulic circuit adopts a stacking valve installation method, which is compact in structure and convenient to install. The pressure of each hydraulic cylinder of the hydraulic system can be adjusted separately and has a pressure protection device.

## Main Structure

### Protective Guard

The machine adopts fully enclosed safety guard, which occupies a small space and is convenient for forming an automatic production line.

### Cooling System

The machine's cooling pump uses a high lift cooling pump. The cooling water is taken out by the cooling pump and divided into two paths through the cooling pipe: one is connected to the nozzle on the tool post and sprayed through the nozzle of the tool holder; the other is connected with the multi-head cooling water pipe on the protective guard to achieve high-flow cooling effect. It has good maintainability and good leakproof performance.

### Electrical System

The machine control system uses the FANUC Oi TF system, and the two-axis feeding motor uses the FANUC AC synchronous servo motor.

The electrical design of the machine complies with the electrical standard of GB5226.1-2002.

The power circuit of the circuit has over-current and short circuit protection, and the machine related actions have corresponding interlocks to ensure equipment and personal safety.

The electrical system has a self-diagnostic function, and the operation and maintenance personnel can observe the operating status of the machine each part at any time according to the indicator light and the display.

The main electrical components of the machine tool are imported, thus ensuring the safety and reliability of the machine.

The appearance of the control cabinet is beautiful, the line number is clear and complete, and the wiring is neat; the connection of the electrical cabinet to the bed is all connected by dedicated cable.

The standard configuration of the electrical cabinet adopts a fully enclosed structure and is equipped with an electric cabinet air conditioner to achieve the purpose of dust-proof and cooling. The electrical cabinet protection level meets the IP54 requirements; and a certain space is reserved in the electrical cabinet to facilitate the expansion of functions.

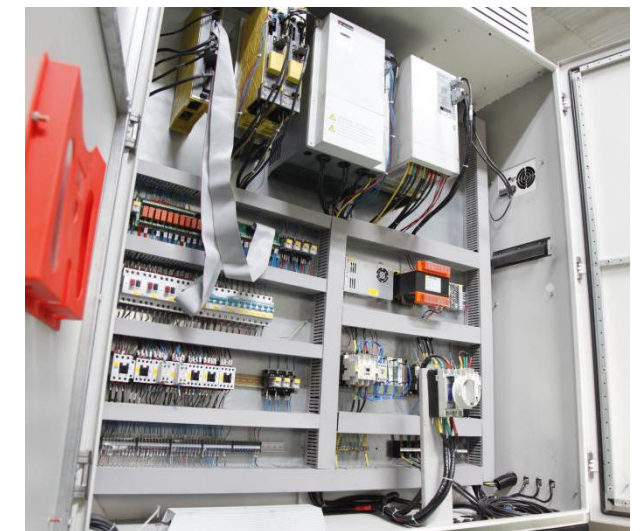

## Main Structure

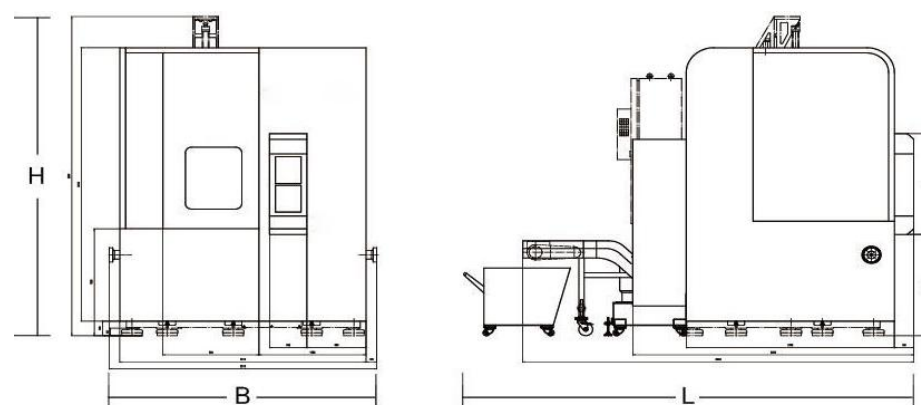
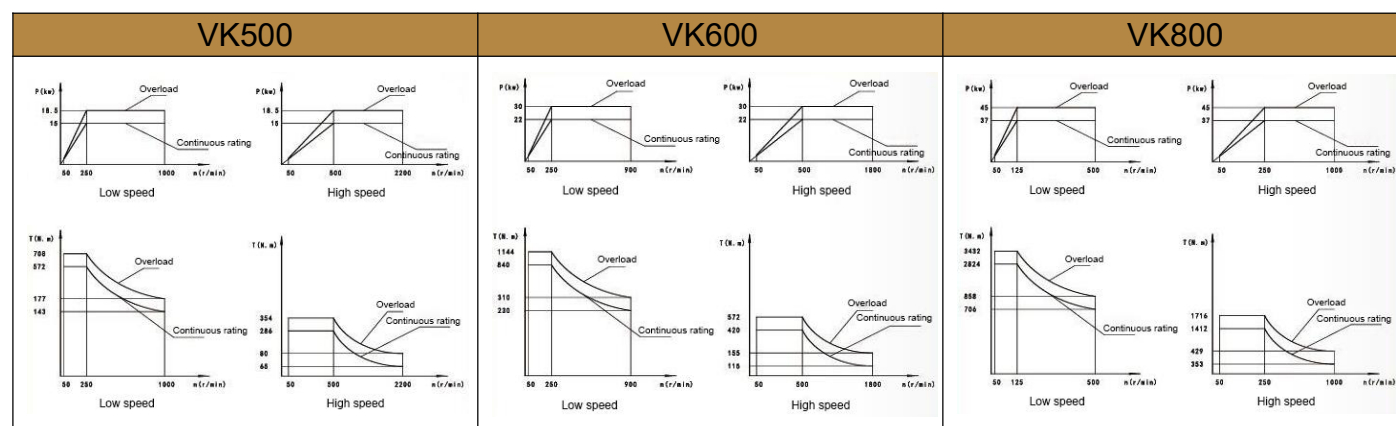

Unit: mm

Machine Size			
Model	L	W	H
VK500	2357	2970	3150
VK600	3350	2800	3420
VK800	2960	3920	3671

VK-series Working Accuracy				
Model	Unit	VK500	VK600	VK800
Working accuracy	mm	IT6	IT6-IT7	IT6-IT7
Roughness	um	Ra1.6	Ra1.6	Ra1.6
X-axis positioning accuracy	mm	0.012	0.018	0.018
Z-axis positioning accuracy	mm	0.015	0.02	0.02
X-axis repeat positioning accuracy	mm	0.006	0.006	0.0075
Z-axis repeat positioning accuracy	mm	0.006	0.008	0.015

## Technical Parameter

Specification	Unit	VK500	VK600	VK800
<b>Capacity</b>				
Max. swing diameter	mm	Φ500	Φ800	Φ1000
Max. turning diameter	mm	Φ400	Φ600	Φ800
Max. height of workpiece	mm	480	700	800
<b>Spindle</b>				
Chuck diameter (hydraulic)	mm	325(12")	530(21")	610(24")
Spindle nose	-	A2-8	A2-11	A2-15
Spindle bearing diameter	mm	160	180	200
Worktable speed steps	-	two shifts, stepless	two shifts, stepless	two shifts, stepless
Spindle speed range	rpm	50-2200	50-1800	50-1000
Worktable torque	N.m	500	840	2200
<b>Feed</b>				
X-axis rapid feed speed	mm/min	10000	10000	10000
X-axis feed speed	mm/min	0.1-1000	0.1-1000	0.1-1000
Z-axis rapid feed speed	mm/min	15000	15000	15000
Z-axis feed speed	mm/min	0.1-1000	0.1-1000	0.1-1000
Min. feed unit	mm	0.001	0.001	0.001
<b>Travel</b>				
X-axis travel	mm	-50~250	-50~650	800
Z-axis travel	mm	500	625	850
<b>Tool turret</b>				
Turret type	-	horizontal 8station	horizontal 8station	horizontal 8station
Size of tool shank	mm	25x25; Φ40	25x25; Φ40	32x32; Φ50
<b>Power</b>				
Main motor power	kw	15/18.5	22/26	37/45
X-axis servo motor power	kw	1.8	3	3
Z-axis servo motor power	kw	3	3	4.2
Cooling pump power	kw	0.75	0.75	0.75
<b>Others</b>				
Machine dimensions (LxWxH)	mm	2357x2970x3150	3350x2800x3420	2960x3920x3671
Machine weight	kg	11000	13000	15000





VK series  
Overall Machine

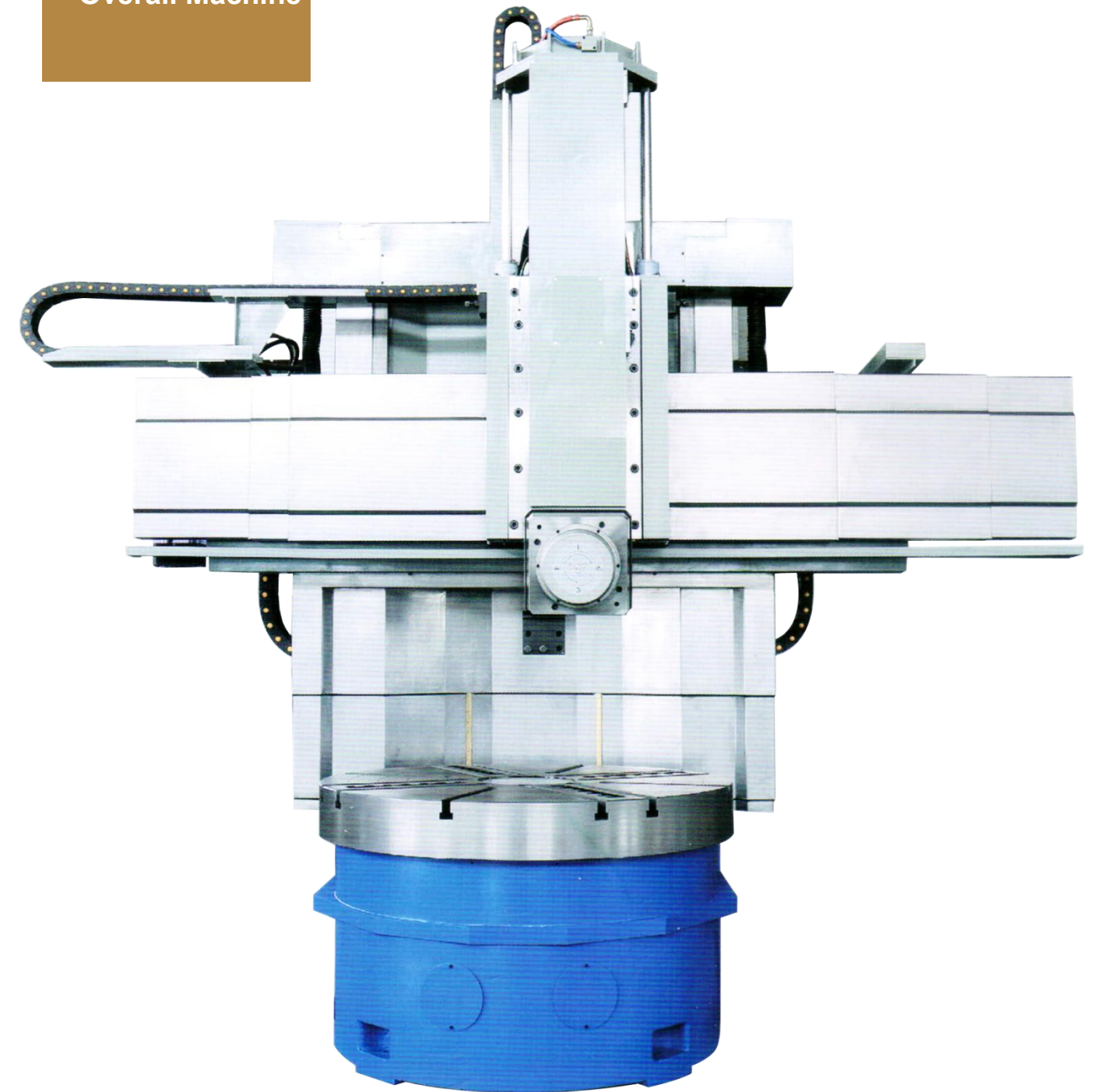

## VK series Tool Magazine



## Main Structure

### Column

The column is a thermal symmetrical structure with the whole cross ribs closed. The material is made of high-strength and low-stress cast iron and adopts effective vibration-damping measures. The column is connected to the base of the workbench and then made on the basis. The mutual engagement form can effectively insulate, isolate the vibration, and fit the structure, which greatly improves the overall rigidity and vibration resistance of the machine tool. The column guide surface is quenched and ground, and the quenching hardness is 45-55HRC.

A beam lifting mechanism is installed at the upper end of the column, and the double-screw AC motor drives the double screw to drive the beam to lift. The lower end rail of the beam is fitted with a stainless steel rail guard.

### Main Drive System

The spindle is driven by a vertical type AC asynchronous servo main motor that is mounted behind the column via a motor bracket. The main motor and the table II shaft are driven by a narrow V-belt, which drives the helical gear to mesh with the large ring gear. The speed of the motor is adjusted by adjusting the motor speed. The main motor is a two-speed servo spindle motor with a two-speed ratio of 1:1 and 1:4, respectively, and a fixed speed of 250/1000 rpm. The two-speed spindle servo drive system has better mechanical characteristics than the ZF series reducer system and the DC motor plus gearbox. It can replace the ZF series reducer and gearbox, eliminating the maintenance and maintenance of the reducer and gearbox. Cost saving reduces noise, protects the environment, and has good economic and social benefits. The two-speed spindle servo drive system has closed-loop speed regulation in the whole speed range, with 1.5 times overload capability, and can output effective torque at zero speed.

### Beam

The beam is composed of horizontal feed mechanism of the tool holder, beam clamping mechanism and hydraulic device. The end of the beam is combined with an automatic lubrication station, adopts timed quantitative lubrication method.

The horizontal feed mechanism with vertical tool holder at the right end of the beam is driven by AC servo motor. It is directly connected with the ball screw through the 1:4 reducer to drive the ball screw to rotate, so that the vertical tool holder can achieve horizontal feed and fast. mobile. The X-axis is equipped with a HEIDENHAIN encoder.

The beam guide adopts the intermediate guide, and the beam has two clamping points, which are in the form of mechanical and hydraulic joint clamping.

The front rail of the beam is equipped with a telescopic stainless steel shield, and the lower part of the rail is equipped with an oil tank.

The horizontal rail of the beam is guided by the lower rail surface of the upper rail and the upper rail surface of the lower rail, and the ball screw is in the middle of the guiding rail to completely solve the problem of driving torsion moment. The beam guide surface is quenched and ground, and the quenching hardness reaches 45-55HRC.



## Main Structure

### Worktable

The entire part of the table is thermally symmetrical. It consists of a work table, a table base, a spindle, a spindle bearing, and a large ring gear. The main shaft bearing adopts a conical crossed roller bearing structure, which has the characteristics of high precision, high rigidity, high load bearing, high speed and low friction. This gives the machine itself a high degree of rotational precision and rigidity.

The connecting plate is made of cast iron, and each geometric surface is mechanically processed and statically balanced; the working platform drive shaft and transmission parts are balanced to ensure that the table vibration is small when rotating at high speed.

The table base is equipped with a spindle encoder for constant line speed cutting.

A flow transmitter is installed on the hydraulic system oil line to stabilize the flow of the hydraulic oil and protect the worktable rail from damage.

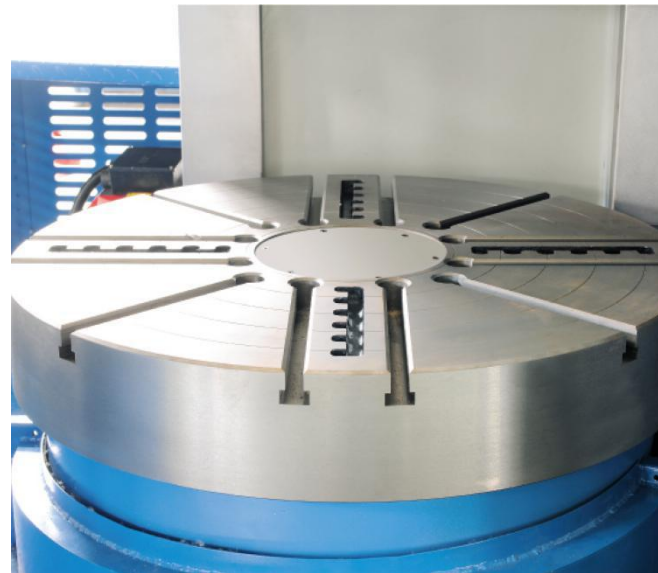

### Cooling System

The machine is equipped with a cutting and cooling circulation system to cool the tool and the workpiece. The cooling water tank is arranged outside the main machine to facilitate the entry and return of water.

The coolant is output from the cooling box to the tool holder at the lower end of the tool holder ram through the drag chain, and the tool and the workpiece are cooled. The coolant and iron chips are separated and flowed back to the cooling box through the discharge port. After filtration, purification and recycling .

### Chip Removal and Protection Guard

The machine is equipped with an enclosed protective cover and the protective cover is designed with a European design concept. The height of the shield ensures that the coolant and iron scrap will not spill. The shield has the protection and collection function of iron filings and coolant. The shield has enough space for chip cleaning.

The machine is equipped with an automatic chip evacuation device, which uses side chip removal.

## Main Structure

### Vertical Tool Post

The vertical tool post consists of beam slide, rotary slide and ram.

The vertical tool post can be horizontally moved on the beam and the ram is moved vertically. The X-axis and Z-axis are driven by the AC servo motor. The motor and the ball screw are directly connected by the flexible coupling. The X-axis and Z-axis adopt the reinforced linear roller guide, it has extremely high rigidity and sharp dynamic response in the cutting state. By adding the HEIDENHAIN grating scale, the two-axis linkage full-closed control is realized.

The ram has a T-shaped cross section and is made of ductile iron. The ram rail surface is quenched and ground, and the quenching hardness reaches 45-55HRC. The sliding surface is in contact with the beam and the ram.



The lower end of the ram is equipped with a four-stations electric turret. The turret use the AK27-QY series electric CNC turret tool holder produced by Yantai Global Machine Tool Accessories Group Co., Ltd. The turret is a motor built-in CNC turret specially designed and manufactured by our company according to the production requirements of our company. It is characterized by high-precision hardened triple-toothed disc sub-positioning. Good precision retention, high positioning accuracy, no need to lift when indexing, and fast indexing speed. The turret is rigid and has a large braking force and can withstand large cutting forces.

The tool holder vertical feed motor (Z-axis) has a brake to prevent the machine from being powered off.



## Main Structure

### Hydraulic System

The hydraulic system includes: hydraulic system, main drive shifting system, beam clamping system, vertical tool holder ram hydraulic balance system, broach relaxation system and so on.

The hydraulic tank has sufficient capacity to ensure that the temperature change of the hydraulic system does not affect the accuracy of the machine, and the oil temperature control box is configured.

### Electrical System

The machine control system uses the FANUC Oi TF system, and the two-axis feeding motor uses the FANUC AC synchronous servo motor.

The electrical design of the machine complies with the electrical standard of GB5226.1-2002.

The power circuit of the circuit has over-current and short circuit protection, and the machine related actions have corresponding interlocks to ensure equipment and personal safety.

The electrical system has a self-diagnostic function, and the operation and maintenance personnel can observe the operating status of the machine each part at any time according to the indicator light and the display.

The main electrical components of the machine tool are imported, thus ensuring the safety and reliability of the machine.

The appearance of the control cabinet is beautiful, the line number is clear and complete, and the wiring is neat; the connection of the electrical cabinet to the bed is all connected by dedicated cable.

The standard configuration of the electrical cabinet adopts a fully enclosed structure and is equipped with an electric cabinet air conditioner to achieve the purpose of dust-proof and cooling. The electrical cabinet protection level meets the IP54 requirements; and a certain space is reserved in the electrical cabinet to facilitate the expansion of functions.

### Safety Protection

The machine has full shield protection and considers a number of safety protection measures, such as: electric control cabinet safety lock, reinforced glass design of the protective door to ensure mechanical and personal safety.

When the machine tool encounters a sudden power failure or its own fault, due to the special design of the control circuit, if the machine's feeding axes, and the cooling motor is in the "start" state, it will enter the "stop" state; If in the "stop" state, it is not possible to enter the start up state by itself, ensuring the safety of the machine.

The machine tool has an alarm device and an emergency stop button to prevent damage to the machine tool caused by various sudden failures.

CNC machines are strictly required for power supply. When the grid voltage fluctuation exceeds  $AC380V \pm 10\%$  and the frequency exceeds  $50Hz \pm 1Hz$ , the power supply regulator must be added, otherwise it will affect the normal operation of the CNC machine.

## Technical Parameter

Specifications	Units	VK1250	VK1600	VK2000
<b>Capacity</b>				
Max. swing diameter	mm	Φ1400	Φ1650	Φ2050
Max. turning diameter	mm	Φ1250	Φ1600	Φ2000
Max. height of workpiece	mm	1000/1250/1400	1000/1250/1400	1250/1400/1600
Max. weight of workpiece	kg	5000	8000	12000
<b>Spindle</b>				
Worktable diameter	mm	1200	1450	1800
Max. torque of spindle	KN.M	6	10	12.5
Spindle speed steps	-	two shifts, stepless	two shifts, stepless	two shifts, stepless
Spindle speed range	rpm	5~500	5~315	2~250
<b>Tool post</b>				
Vertical tool post max. cutting force	KN	16	20	20
Size of tool shank	mm	16, 32, 40	16, 32, 40	16, 32, 40
<b>Feed</b>				
Z-axis feed speed steps	mm/min	stepless	stepless	stepless
Z-axis feed speed range	mm/min	0.1-1000	0.1-1000	0.1-1000
Z-axis rapid feed speed	mm/min	6000	6000	6000
<b>Travel</b>				
X-axis travel	mm	-100~900	-100~995	-100~1240
Z-axis travel	mm	650/800	800/1000	800/1000
<b>Beam</b>				
Max. travel	mm	650/900/1050	650/900/1050	900/1050/1250
Lifting speed	mm/min	440	440	440
<b>Power</b>				
Main motor power	kw	S1: 25, S2: 30	S1: 30, S2: 37	S1: 35, S2: 45
Beam lifting motor power	kw	3	3	5.5
X/Z-axis motor torque	Nm	20	20	27/20
<b>Other</b>				
Ram sectional size	mm	210x330	215x350	215x350
X/Z-axis guideway type	-	Sliding	Sliding	Sliding
Worktable guideway type	-	Taper rolling rail	Taper rolling rail	Taper rolling rail